

Overview

Passive Wall Mounted Infrared and Microphonic Occupancy Sensing

The Sensor Switch® WV-PDT-R is a passive dual technology (infrared and microphonic) wall mounted occupancy sensor that is compatible with Lumisys lighting panels and Qwik-Kits. Typically, occupancy sensors are installed with a remotely mounted relay / power pack to provide automatic lighting control. Lumisys exceeds this standard by integrating the WV-PDT-R sensor into the Lumisys and Building Automation System.

Easy integration of occupancy sensor status into Building Automation System for:

- Setback of cfm and / or temperature for reduced energy consumption
- Ability to monitor and trend occupancy data to identify opportunities for energy savings, increased comfort and security



WV-PDT-R
Wall Mount Sensor

Green Impact

Existing Buildings

System	Category	Prereq.	LEED Credit
EB	SS	-	7
EB	EA	2	1,6
EB	IEQ	-	6,8
EB	IUOM	-	1

New Construction

System	Category	Prereq.	LEED Credit
NC	SS	-	8
NC	EA	2	1
NC	MR	-	5
NC	EQ	-	6,8
NC	ID	-	1



Ordering Information

Catalog #	Description
WV-PDT-R	Sensor Switch® Passive Dual Technology (Infrared and microphonic), 6 Wire, Wall Surface Mount

Optional Accessories	Catalog #	Description
	WV-BR	Ceiling mounting bracket

Specifications:

Electrical

Power 24 VAC, 13mA, supplied by Lumisys Panel or Qwik-Kit Controller.
Up to 37 WV-PDT-R sensors can be powered from a single Lumisys Controller

Outputs 2-wire Maintained Dry Contact

Mechanical

Dimensions Size: Rectangular, 3.0" x 3.6" x 1.75"
Sensor Weight: 5 Ounces
Sensor Color: White

Mounting Mounting Height 8 to 10 Feet
Wall Surface or Ceiling mounting bracket

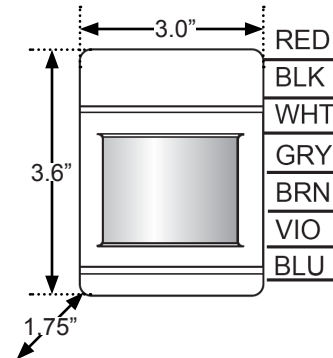

Environmental

Operating Temperature 14-160° F
Operating Humidity 20% - 90% RH, Non-condensing

Wiring

Automatic ON/OFF

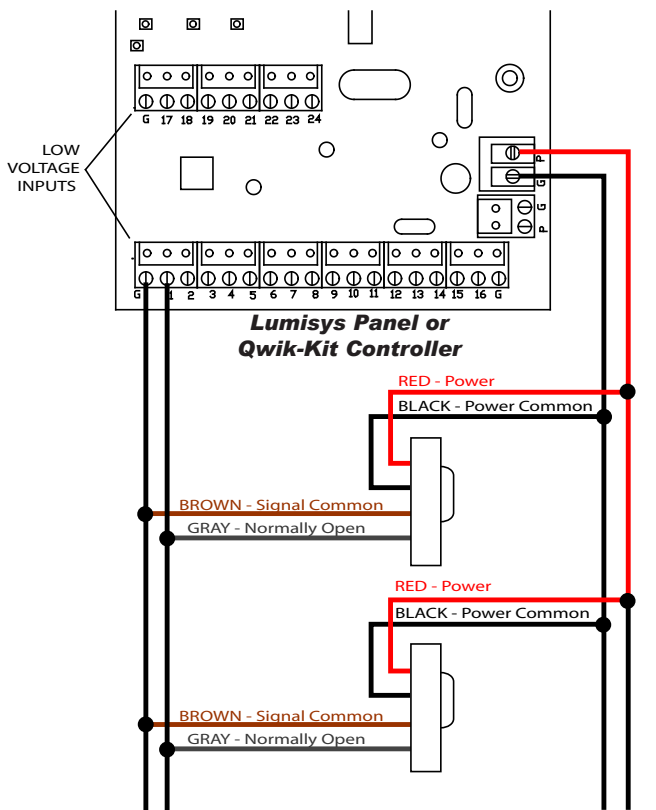

Up to 37 WV-PDT-R Sensors

WV-PDT-R Sensors wired in parallel as shown here cause the same group of lights to be controlled ON or OFF whenever any sensor in the circuit detects occupancy.

One or more sensors can be wired to separate inputs on the Lumisys panel or Qwik-Kit controller to control a different group of lights. In order for the Building Automation System to monitor an individual sensor, that sensor must be wired to its own input.

Automatic ON/OFF with Manual Override

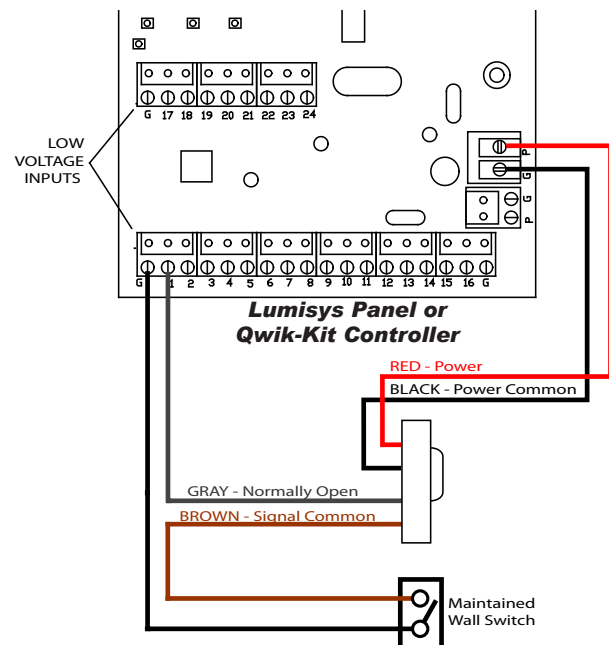

Wiring a low voltage wall switch in series with the WV-PDT-R sensor as shown here enables the sensor to control lights only when the wall switch is ON. When the wall switch is OFF detections from the WV-PDT-R will not be received by the lighting panel, and thus, the lights will not be controlled to ON or OFF.

Note on Power Requirements: If your application currently includes a Lumisys Digi-Touch Network (DDN) powered by the DDN-L, a separate power supply is required for CM-PDT-R occupancy sensors. Contact Lumisys provider to purchase a separate transformer.

