

Overview

Relay Panel (RP) is a UL Listed lighting control panel. RP may be scheduled from any BACnet BAS and is compatible with all low voltage switches as well as occupancy sensors. RP mounts near the circuit breaker panel to provided centralized control of branch lighting circuits. Relay Panel 64 (RP64) features 40 to 60 Lighting Tough Relays (LTR) in a black powder coated steel enclosure with a hinged reversible door.

Features

UL Listed

BACnet MS/TP and N2 communication to BAS network

Sub network for Capacitive Touch Stations (CTS-DDN)

Line and low voltage compartment separation

Upgradable controller firmware

Available options:

- Low/Line Voltage Bays
- Multi-pole Lighting Contactors
- 24VAC Auxiliary Transformer
- 24VDC Power Supply
- BACnet IP Router
- UL924 Emergency Bypass
- 347VAC Transformer

General Specifications

Construction: 16ga steel with black powder coat finish

Dimensions:

Enclosure: 42.60"(1082mm)H x 18.00"(457mm)W x 5.75"(146mm)D

Door Surface Mount: 42.85"(1088mm)H x 18.08"(459mm)W

Door Recessed (Flush): 44.10"(1120mm)H x 19.58"(497mm)W

Weight: 82.5lbs(37.4kg)

Mounting: Surface or recess mounted

Operating Environment: 32-125°F (0-50°C), 20-95%RH, non-condensing, NEMA 1 (dry / indoor environment)

Certifications

UL Listed, UL916 Standard for Energy Management Equipment, US/Canada FCC Part 15

CEC Title 24

Electronics meet or exceed IEC Level 3

Warranty

Two (2) year limited manufacturer warranty from date of shipment (extended warranty optional).

Controller Specifications

Power In: 24VAC +/-10%, 30VA, 50-60 Hz

Auxiliary Out: 24VAC Full Wave Rectified

Digital Input: 24 two-wire inputs

Software Configuration: Maintained, state change, momentary on/off, momentary on, or momentary off

Jumper Configuration: 8 input segments, dry contact (N) or 24VDC externally powered (R)

Wire Requirement / Maximum Length: 18AWG (Solid or Stranded) / Dry Contact 500'(152m) or externally powered 1,000'(304m)

Analog Input: 6 three-wire 0-5VDC inputs

Wire Requirement / Maximum Length: 18AWG (Solid or Stranded) / 250'(76m)

BAC Network Specifications

BACnet MS/TP

Baud Rate: DIP switch selectable 9.6K, 19.2K, 38.4K, or 76.8K

Device Profile: BACnet Advance Application Controller (AAC)

Address Range: 1 – 99 selectable with rotary dials

Unit Load: Full unit load, 32 devices per MS/TP segment

N2

Baud Rate: DIP switch selectable 9.6K

Address Range: 1 – 255 selectable with rotary dials and DIP switch



BACnet MS/TP and N2

Topology: RS-485, 3 conductor (+, -, and shield), daisy chain wiring (no stars or t-taps)

Wire Requirement / Maximum Length: Belden 8760 / 4000'(1216m)

Points: See RP Application Guide and PIC Statement

DDN Network Specifications

Compatible with CTS-DDN and DDN devices. See data sheet for details.

LEXP Specifications

Description: 1 Digital Input Expansion Card (standard)

Digital Input: 32 two-wire inputs

Software Configuration: Maintained, state change, momentary on/off, momentary on, or momentary off

Jumper Configuration: 8 input segments, dry contact (N) or 24VDC externally powered (R)

Wire Requirement / Maximum Length: 18AWG (Solid or Stranded) / Dry Contact 500'(152m) or externally powered 1,000'(304m)

Transformer Specifications

Type: 30VA Inherently Limited

Primary: Dual Tap 120 or 277VAC +/-10%, 30VA, 50-60 Hz

Secondary: 24VAC +/-10% Inherently Limited

Wire Requirement: 18AWG Minimum (Solid or Stranded)

LTR Specifications

Type:

UL Listed

SPST latching with manual override lever

Electrically operated mechanically held, pulse driven

Short Circuit Current Rating (SCCR) 30,000A @ 277 VAC

Ratings: Tungsten 20A @ 120VAC / Ballast 20A @ 277VAC / Ballast 20A @ 347VAC / Resistive 20A @ 277VAC / Resistive 20A @ 347VAC

Load Terminal: Universal screw terminal, box type clamp

Terminal Capacity (per side): (2) 14-10AWG or (1) 8AWG (Solid or Stranded copper wire)

Optional Equipment Specifications

See Relay Panel Optional Equipment Data Sheet

Relay Panel 64

www.BRTint.com : 800-241-9173 Blue Ridge Technologies® © 2012 Blue Ridge Technologies International, LLC All Rights Reserved. BRT-RP64-DS-V11.00

Data Sheet : Catalog Page 13

General Architecture

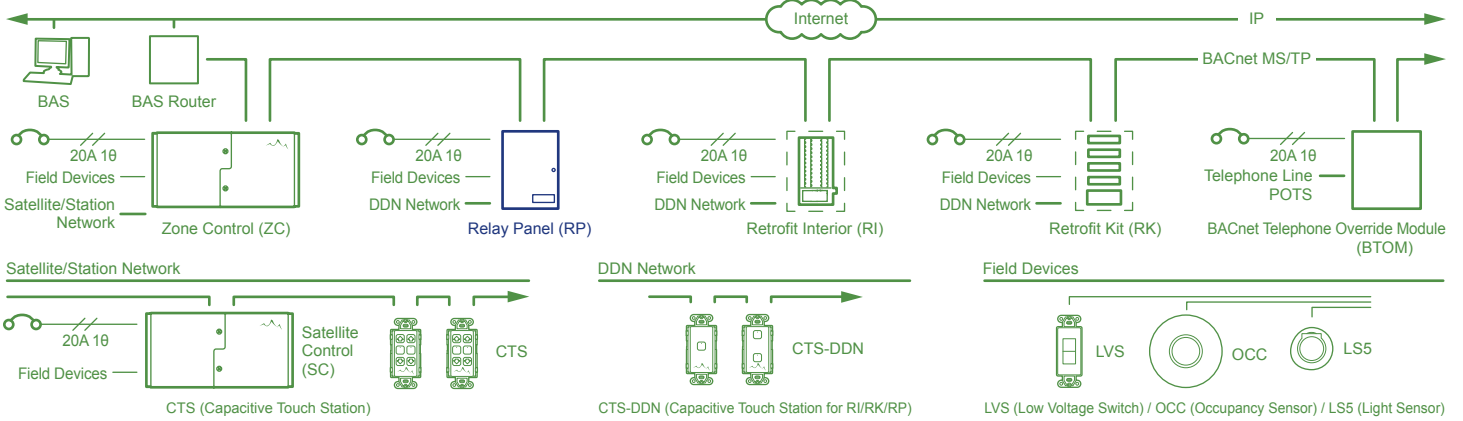

Controller Terminations

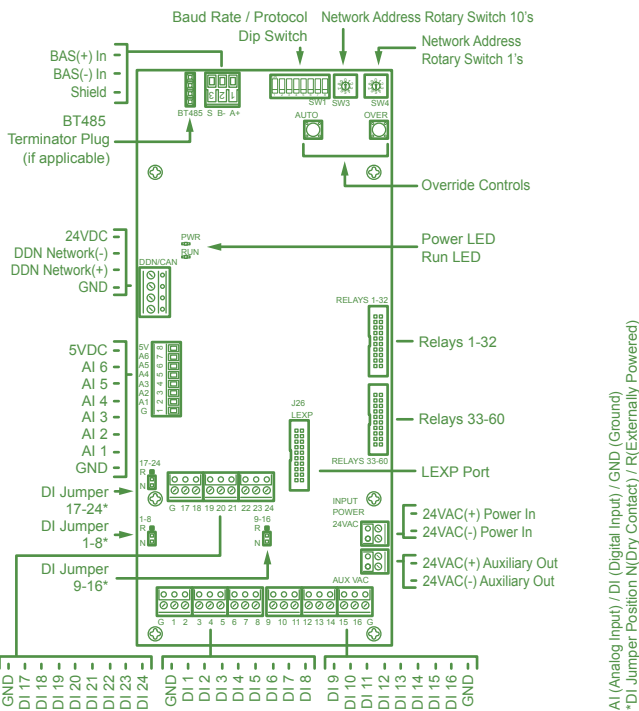

Ordering Information

BR64P - XX - XX - XX - XX

Actual Quantity of Relays Installed
XX = 40 thru 60 Between 40 and 60 Relays Installed**

Special Options
XX = 00 None
IP BACnet IP Router*
X0 UL924 - Last 16 relays only
0C 347VAC Transformer
XP BACnet IP Router + UL924*
XC UL924 + 347VAC Transformer
IC BACnet IP Router + 347VAC Transformer*
AA BACnet IP router + UL924 + 347VAC Transformer*

Low Voltage Section at Bottom of Panel
XX = 0L None
1L 9" Bay
1A 9" Bay + 30VA Transformer
1G 9" Bay + 2.5A 24VDC PS
1M 9" Bay + 30VA Transformer + 2.5A 24VDC PS

Line Voltage Bay at Top of Panel with Dead Front Cover
XX = 0H None
1H 9" Bay
1A 9" Bay + (1) 4 Pole 30A Electrically Held Lighting Contactor, 120V Coil
1B 9" Bay + (2) 4 Pole 30A Electrically Held Lighting Contactor, 120V Coil
1C 9" Bay + (3) 4 Pole 30A Electrically Held Lighting Contactor, 120V Coil
1D 9" Bay + (1) 4 Pole 30A Electrically Held Lighting Contactor, 277V Coil
1E 9" Bay + (2) 4 Pole 30A Electrically Held Lighting Contactor, 277V Coil
1F 9" Bay + (3) 4 Pole 30A Electrically Held Lighting Contactor, 277V Coil

* BACnet IP Router requires Low Voltage Bay ** Relays 61-64 for future development.
*** See Pricing Guide for Recessed (Flush) door panels.

Transformer Terminations

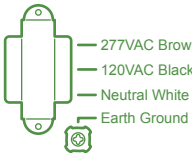

LTR Terminations

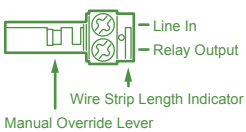

LEXP Terminations

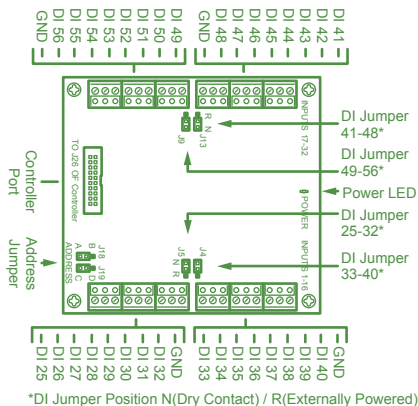

*DI Jumper Position N(Dry Contact) / R(Externally Powered)