



## Overview

Lighting Tough Relay (LTR) is a UL Listed electrically operated mechanically held SPST latching relay. LTR is standard on Retrofit Interior (RI) and Relay Panel (RP) platforms. LTR may be ordered individually and field installed to expand circuit capacity.

## Features

- UL Listed
- Compatible with RI, RK1, and RP
- Includes all mounting hardware

## General Specifications

Dimensions: 1.00" (25mm) H x 2.63" (67mm) W x 2.00" (51mm) D  
 Weight: 2oz (59g)  
 Mounting: (1) #4-40 screw (included), fastens to factory mounting points  
 Operating Environment: 32-125°F (0-50°C), 20-95%RH, non-condensing

## Certifications

UL Listed component E-175678, US/Canada  
 Maintains RI / RP UL Listing and all certifications

## Durability

Mechanical Life Operations: 1,000,000  
 Full Load Operations: 300,000

## Warranty

Two (2) year limited manufacturer warranty from date of shipment  
 (extended warranty optional)

## Relay Output Specifications

Contact Type: SPST latching with manual override lever  
 Contact Operation: Electrically operated mechanically held, pulse driven  
 Ratings:

- Tungsten 20A @ 120VAC
- Ballast 20A @ 277VAC
- Ballast 20A @ 347VAC
- Resistive 20A @ 277VAC
- Resistive 20A @ 347VAC

Load Terminal: Universal screw terminal, box type clamp  
 Terminal Capacity (per side): (2) 14-10AWG or (1) 8AWG (Solid or Stranded copper wire)

# Lighting Tough Relay

www.BRTint.com : 800-241-9173 Blue Ridge Technologies® © 2014 Blue Ridge Technologies International, LLC All Rights Reserved. FN-LTR-DS-V14.02

Data Sheet

## General Architecture

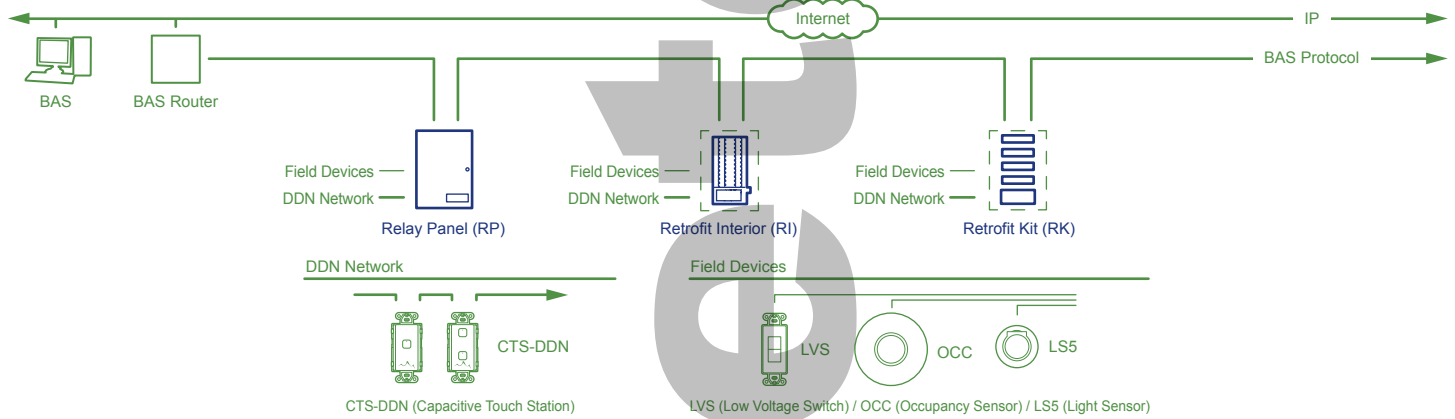

## LTR Terminations

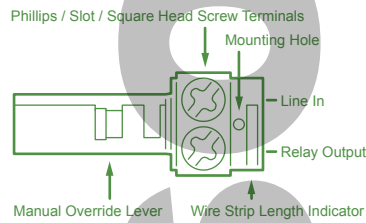

## Ordering Information

Part Number	Description
FNLTR1	Lighting Tough Relay for field installation