



Overview

BACnet Telephone Override Module (BTOM), allows users to override lighting and/or HVAC utilizing any push button telephone. BTOM's interface utilizes human voice prompts to guide user selection of up to 6 hours of override time for 1,022 zones.

BTOM is customizable to suit various applications. Default English voice prompts may be rerecorded in any style or language. All Unit Numbers, passwords, and administrator functions may be programmed to suit any installation while providing user validation required for tenant billing purposes. BTOM supports BACnet MS/TP and custom integration for various control options.

Features

UL Listed
Compatible with any push button telephone
BACnet MS/TP communication to BAS network

Sequence of Operations

1. User dials the BTOM utilizing any push button telephone.
2. BTOM Prompt 1 "Please enter your Unit Number followed by the # sign."
3. User dials 4 digit Unit Number. Each Unit Number represents a zone to override.
4. BTOM Prompt 2 "Enter your password followed by the # sign."
5. User dials 4 digit password.
6. BTOM Prompt 3 "Enter 1 through 6 for override hours or 7 for off."
7. User dials 1-6 to override lighting and/or HVAC for up to 6 hours.
8. BTOM Prompt 4 "Your request has been submitted. You may make additional entries."
9. User may hang up or enter additional overrides.
10. The BTOM then exposes the Unit Numbers and Override Times to the BAS for implementation.

General Specifications

Construction: 16ga steel with black powder coat finish
Dimensions:
Enclosure: 14.75"(375mm)H x 13.00"(330mm)W x 5.75"(146mm)D
Door Surface Mount: 14.94"(379mm)H x 13.16"(334mm)W
Weight: 16lbs(7kg)
Mounting: Surface mounted
Operating Environment: 32-125°F (0-50°C), 20-95%RH, non-condensing,
Type 1 (dry / indoor environment)

Certifications

UL Listed, UL508A, Standard for Energy Management Equipment, US/Canada
CEC Title 24
Electronics meet or exceed IEC Level 3

Warranty

Two (2) year limited manufacturer warranty from date of shipment (extended warranty optional)

Controller Specifications

Power In: 24VAC +/-10%, 30VA, 50-60 Hz

BAS Network Specifications

BACnet MS/TP
Baud Rate: DIP switch selectable 9.6K, 19.2K, 38.4K, or 76.8K
Device Profile: BACnet Advance Application Controller (AAC)
Address Range: 1 – 99 selectable with rotary dials
Unit Load: Full unit load, 32 devices per MS/TP segment
Topology: RS-485, half duplex, daisy chain wiring
Wire Requirement / Maximum Length: CL3P, 22AWG, 2 conductor, shielded, low cap / 4000'(1216m)
Points: See Integration Guide and PIC Statement

Telephone Interface Module (TIM) Specifications

Telephone Connection
Plug / Wire Requirement: Male RJ-11 / Plain Old Telephone System (POTS)
Programming Connection
Plug / Cable Requirement : Male pins / RS-232
Interface: PC Terminal Program (Hyper Terminal)
Programming Connection allows user to customize default Unit Numbers, passwords, and Output Timing.
Recording Connection
Plug / Wire Requirement: Male RJ-11 / Plain Old Telephone System (POTS)
Interface: Push button telephone handset
Recording Connection allows user to customize default Voice Prompts.

Transformer Specifications

Type: 40VA Inherently Limited UL Listed
Primary: Multi Tap 120, 208, 240, or 277VAC +/-10%, 40VA, 50-60 Hz
Secondary: 24VAC +/-10% Inherently Limited
Wire Requirement: 18AWG Minimum (Solid or Stranded)

General Architecture

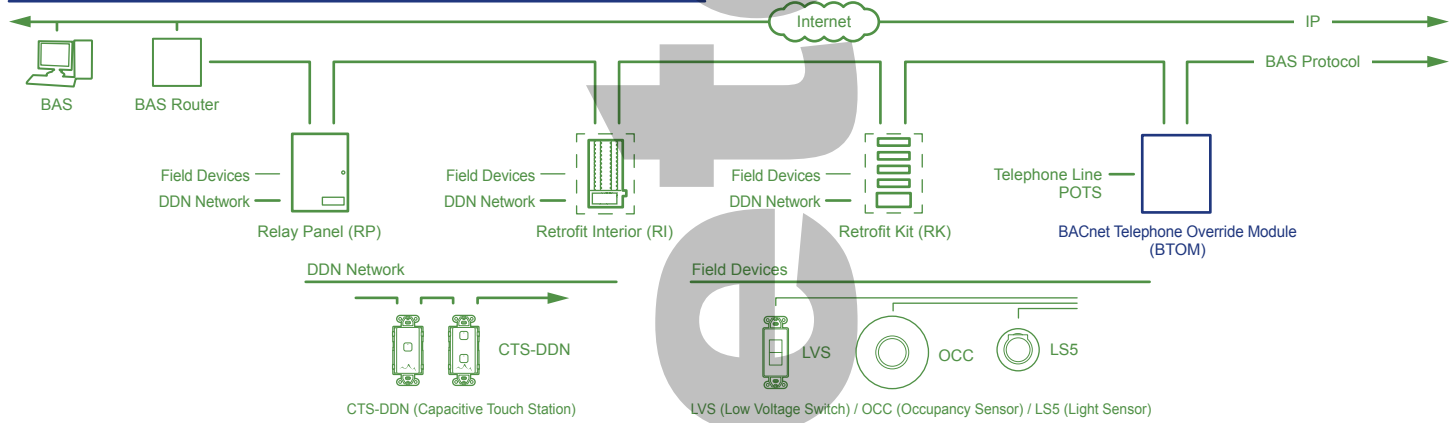

Controller Terminations

TIM Terminations

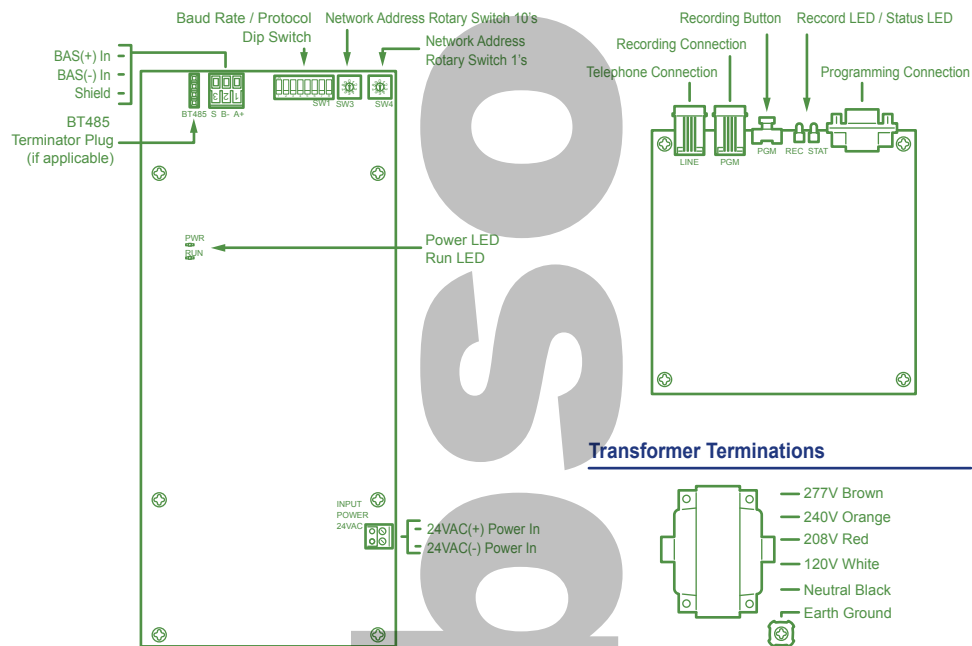

Transformer Terminations

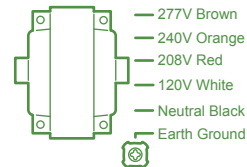

Ordering Information

Part Number	Description
BRBTOM	BACnet Telephone Override Module